



SHENZHEN KHJ SEMICONDUCTOR LIGHTING CO., LTD.

## Operation & Maintenance Manual

### K Firefly Series-V1



<input type="checkbox"/>	Explosion Proof Lighting	Ex db op is IIC T5 or T6 Gb Ex tb op is IIIC T95°C or T80°C Db Ip66
<input type="checkbox"/>	Industrial Lighting	

Add: 4-5 Floor, Building 1,Chuangxin Industrial Park,Xintian community,Guanlan, Longhua new district, Shenzhen, China.

Tel: +86-755-82949977

Fax: +86-755-82949800

Web: www.khjled.com

### 1. Brief Introduction

1.1.LED source, aluminium alloy explosion proof enclosure. Small size, high safety and stability .

### 2. Application

2.1.Ex type: Petroleum Industry, Petrochemical Industry, Metallurgical Industry, Power Generation Industry, Power Transmission Industry, Machine Manufacturing. etc.

Industrial type: Suitable for many indoor and outdoor locations, such as metallurgy laneway, large-scale cable trench, cement plants,power station and moist vibration locations

2.2. Ambient temperature from -40°C to 55°C.

### 3. Executive standard

- 3.1.IEC 60079-0 Electrical apparatus for explosive gas atmospheres- Part 1:General requirements
- 3.2.IEC 60079-1 Explosive atmospheres- Part 2: Equipment protection by flameproof enclosures “d”
- 3.6.IEC 60079-31 Explosive atmospheres- Part 31: Equipment dust ignition protection by enclosure “t”
- 3.5.EN 60079-0 Electrical apparatus for explosive gas atmospheres- Part 1:General requirements
- 3.6.EN 60079-1 Explosive atmospheres- Part 2: Equipment protection by flameproof enclosures “d”
- 3.9.EN 60598-1 Luminaires-Part 1: General requirements and tests
- 3.10.EN 55015 Limits and methods of measurement of radio disturbance characteristics of electrical lighting and similar equipment
- 3.11.IEC 62321 Electrotechnical products - Determination of levels of six regulated substances (lead, mercury, cadmium, hexavalent chromium, polybrominated biphenyls, polybrominated diphenyl ethers)

### 4. Product certification

4.1 .ATEX, IECEx, ABS, RoHs and CE .

### 5. Caution

- 5.1. This product should be installed and maintained by qualified electrician only.
- 5.2. Do not operate in ambient temperatures above those indicated on the nameplate.
- 5.3. Repair of the flameproof joint must be made in compliance with the structural specifications provided by the manufacturer.
- 5.4.The assembly should be equipped with certified cable glands with a compatible mode of protection for the intended use. The unused holes should be closed by certified plugs.
- 5.5. Make sure the electrical power is OFF before making installation and maintenance.
- 5.6. Do not open when energized.
- 5.7.After de-energizing, delay 10 minutes before opening.
- 5.8.Typically full discharging and charging once every half a year.

6.1.This series products have Installation methods:

### 6.Installation method

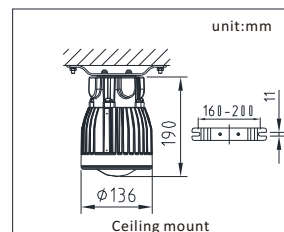
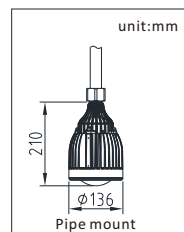

- 6.2.Fix M8 expansion anchor bolts as per different installtion methods.
- 6.3.Fix the installation brackets to the right places on the light and fasten it.
- 6.4.Fix the light to the expansion anchor bolts, and fasten the nuts.

Installation Steps:

1)Pendant mount :

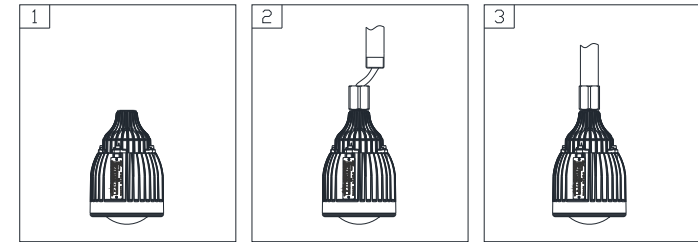

2)Ceiling mount:

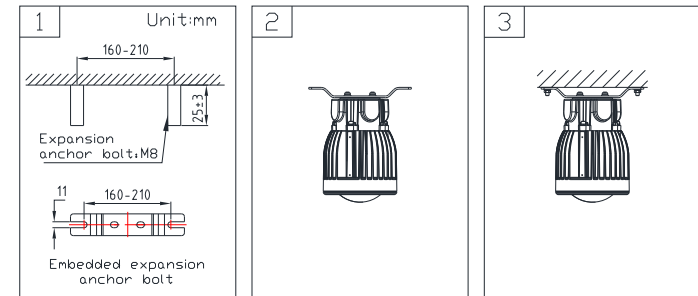

6.5.Wiring:

6.5.1.Use suitable three core cable(OD8-14mm)with stripping length (L:23mm,N:23mm, GND:23mm) as per installation location.

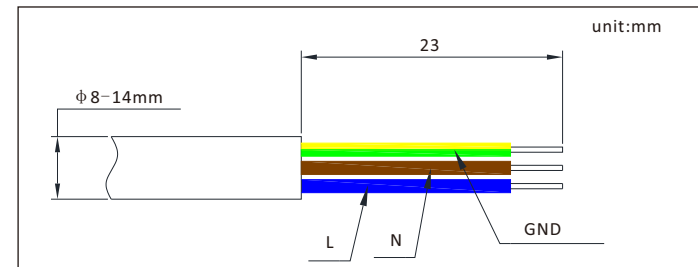

6.5.2.Remove 4pcs M6 screws with hex wrench and open the real cover.

6.5.3.Remove the gland nut, loosen the screws and wire clips.

6.5.4.Put the cable through nut, flat washer, rubber seal and flat washer to the cable terminal.(Please note the order of pipe connector, gasket and rubber seal.)

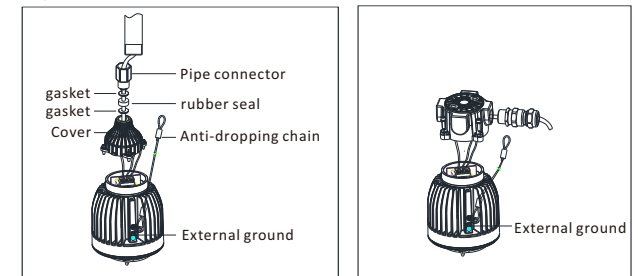

6.5.5. Connect wire L and N to the right terminal, connect the ground wire to the marked position in the terminal compartment.

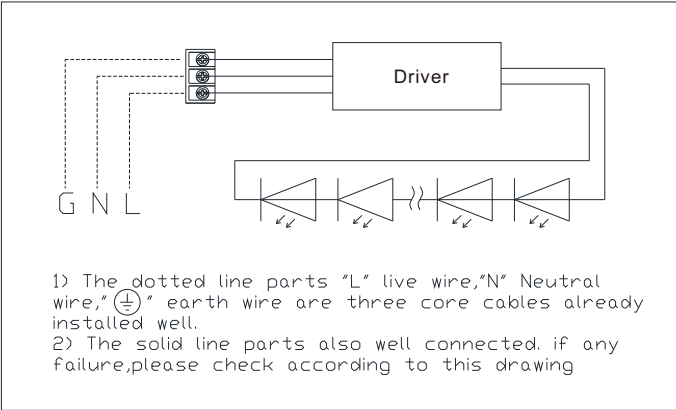

6.5.6. Fix the terminal compartment cover back and fasten the gland nut.

6.5.7. Connect the ground wire to the marked position, and fasten it.

6.5.8. Install the safety chain, one end to the light, the other end to the installing surface.

6.5.9. Connect the luminaire with AC power.

## 7. Operation

7.1. After installation, the luminaire will work while connecting to AC power.

## 8. Maintenance

8.1. Power supply replacement:

8.1.1. Remove the 4 pieces of M6 screws with 4mm hex wrench and open the rear cover.

8.1.2. Remove the 2 pieces of screws with Cross screwdriver, take off the power supply.

8.1.3. Unsolder the cables from the power supply, replace with new power supply.

8.1.4. Solder the cables to the new power supply. Put it into the lighting fixture. Then fix the rear cover.

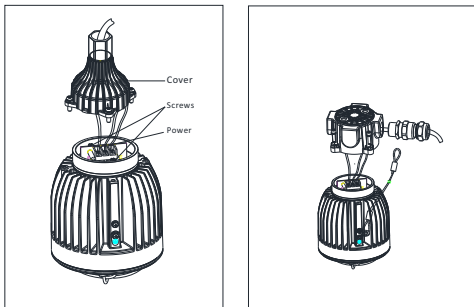

8.2. Replace the LED module:

8.2.1. Open the cover.

8.2.2. Replace the new PCB, fix it, and connect the lead wire between PCB and Power supply.

8.2.3. Then fix the rear cover.

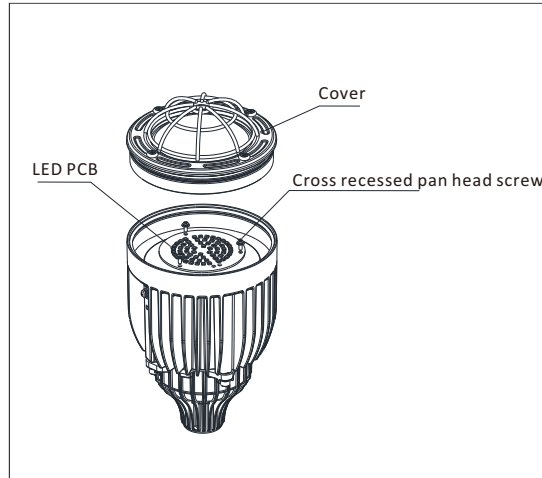

## 9. Optional Parts

NO.	Name	Qty/luminaire	Remark
1	12W Power Supply	1	
2	24W Power Supply	1	
3	35W Power Supply	1	
4	12W PCB	1	
5	24W PCB	1	
6	35W PCB	1	

## 10. Malfunction Diagnosis and Correction

Malfunction Diagnosis	Analysis	Correction
Fail to work	No power	Check the circuit
	LED damaged	Replace LED in secure condition
	Driver damaged	Replace LED driver in secure condition
Other problems		Contact KHJ service center

Do NOT conduct any on-site maintenance .