

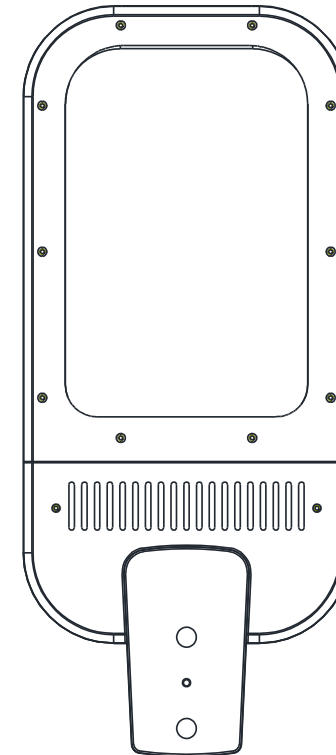

Operation & Maintenance Manual Venus Series-NV1.0



Rev: 01 / 06.01.2022

Contact

SHENZHEN KHJ SEMICONDUCTOR LIGHTING CO., LTD.

Address: 4-5 Floor, Building 1, Chuangxin industrial park, Xintian community, Guanlan, Longhua new district, Shenzhen, China.

Tel: +86-755-82949977
E-mail: khjledsales@khj.cn

Web: www.khjled.com

Fax: +86-755-82949800
Web: www.khjled.com



Important information:

These instructions contain safety information, read and follow them carefully. KHJ will not accept any responsibility for injury, damage or loss which may occur due to incorrect installation, operation or maintenance

Product Important Information

Standards	EN 55015, EN 61547, EN 61000-3-2, EN 61000-3-3, EN 60598-1, EN 60598-2-5, EN 62031, EN 62493, IEC 62321-4, IEC 62321-5, IEC 62321-6, IEC 62321-7-1, IEC 62321-7-2, IEC 62321-8
Certificate	CE, RoHS
Ambient temp	-40°C ≤ Ta ≤ +55°C
Ingress Protection	IP66
Cable entry	/

01.Introduction-Venus Series LED Linear Light

- This user manual covers the range of industrial Venus Series LED luminaire. These luminaires are constructed with corrosion resistant epoxy coated aluminum alloy body and high impact resistance tempered glass diffuser.
- Venus Series LED are available from 80W to 220W, providing ideal solutions for a wide range of industrial applications.

02.Electrical Supplies

Luminaires size:700*320*93mm			
Voltage Range(AC)	100~277VAC (standard)		
Frequency Range(Hz)	50/60Hz		
Power Watts(W)	80W	100W	120W
Standard Current Range(A)	0.28~0.8	0.36~1.0	0.43~1.2
Luminaires size:825*360*93mm			
Voltage Range(AC)	100~277VAC (standard)		
Frequency Range(Hz)	50/60Hz		
Power Watts(W)	150W	200W	220W
Standard Current Range(A)	0.54~1.5	0.72~2.0	0.79~2.2

03.General

- These instructions should be read fully and carefully before attempting to install the luminaire. For details of servicing operations, opening etc.see section 5.
- Copies of these instructions should be held in a safe place for future reference. It is the responsibility of the installer to ensure that the apparatus selected is fit for its intended purpose and that the installation, operation and maintenance of the apparatus complies with applicable regulations, standards or codes of practice. Installation should be carried by qualified electrician only.
- Risk of electrostatic discharge:
 - Avoid mounting near fast moving streams of air
- Any specific installation instructions must be referred to The luminaire should be considered Class I to EN 60598 and effectively earthed.
- The information in this leaflet is correct at the time of publication. The company reserves the right to make specifications changes as required without notice. The luminaire are shipped with the battery pack disconnected, connection must be made on the initial insulation.

3.1 Tools

- 4 mm and 5 mm flat blade screwdriver, large cross head screwdriver and inner hexagon counter wrench, suitable spanners for installing cable gland, pliers, knife, wire stripper and cutter.

3.2 Mounting

- Luminaire should be installed where access for maintenance is practical and in accordance with lighting design information. Refer to the note in 3. concerning electrostatic charge.
- See 5.1 installation diagram for installation mode and method.

3.3 Electrical Connections and Testing

- If any operation is to be done on any luminaire already connected to the electrical system, the luminaire must be isolated from the system.
- To access the mains terminals, loosen the fixing screws, remove the power cover.
- The cable connection method is detailed in 5.2.1. The maximum amount of insulation allowed beyond the throat of the terminal is 4mm².
- The normal method of insulation testing is to connect Live and Neutral together and test between this point. However, if this is not possible luminaire can be tested with an insulation tester that complies with IEC 364 with a maximum output current of 1mA and output voltage of 500V dc. (Units damaged by incorrect insulation testing can be detected).
- Before completing the wiring, ensure that all the connections are correctly introduced into place before reassembling the luminaire.

04.Safety instruction

- Read this leaflet carefully before commencing to install the luminaire unit and retain it for future use. Installation can only be carried out by suitably qualified personnel.
- Check Product Important Information in this user manual to ascertain type of threaded cable entry on the luminaire. Select suitably cable glands and stopper plugs.
- The cable entry devices selected must maintain the IP rating of the luminaire.
- The incoming mains cable should not exceed a temperature rise of 20°C above the ambient conditions; select suitable cable.
- External fasteners must have a yield strength of at least 450N/mm²
- The luminaire must not be operated without all the individual LED covers in position, the IP66 rating must be maintained.

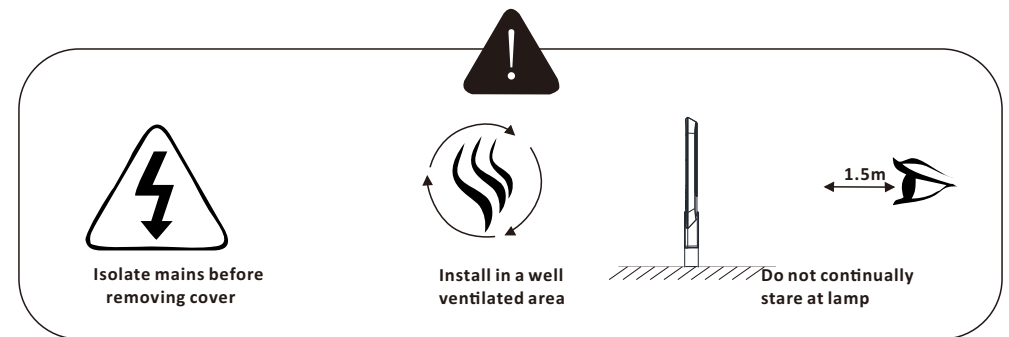

05. Installation method

Based on the use of the scene and actual requirements, we have designed the following installation methods for customers to choose from (including but not limited to) :

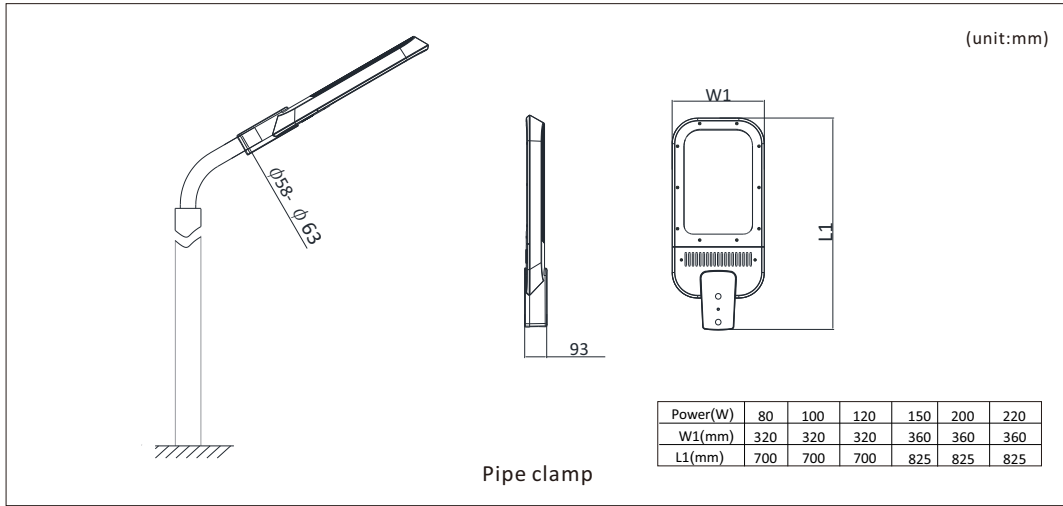

- Remarks:
- External grounding cable cross-sectional area is not less than 4mm².
 - Entries into enclosures torque of locking cable introduction device 35 N.M~40 N.M.

5.1 Installation decomposition

- Pole mount

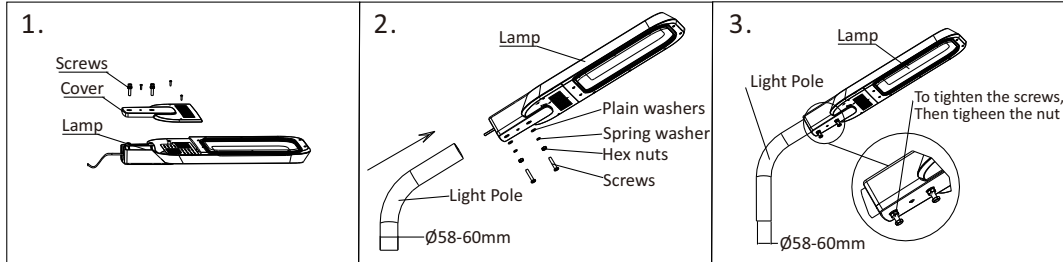

Note: the size of the structure is for reference only. We reserve the right to optimize and adjust some parts of the structure without notice.

5.2 Electrical Principles and Connections

In addition to referring to the relevant contents of this manual, When installed, ensure that the luminaire is effectively grounded (internal or external).

5.2.1 Electrical Principles

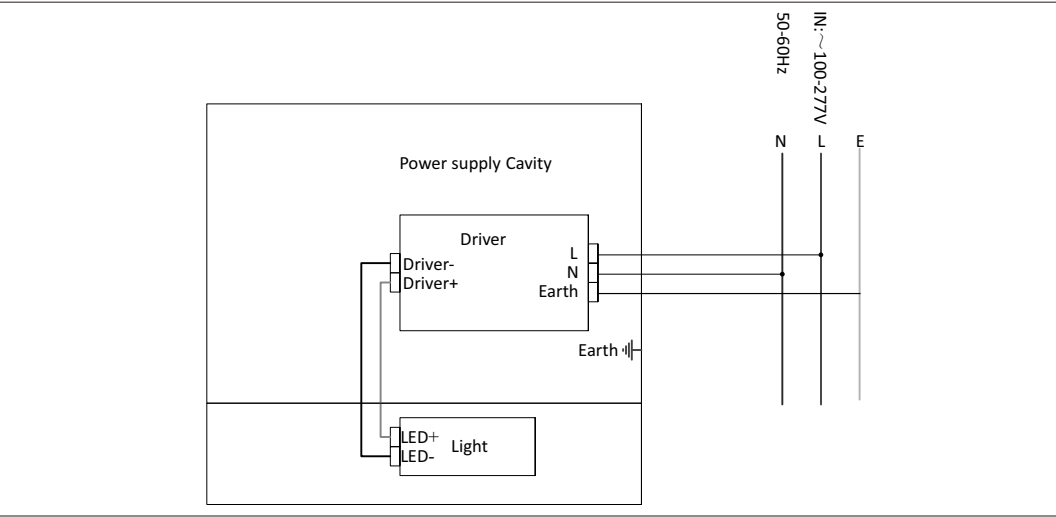

5.3 Cascade

MCB Type	Rating	80W	100W	120W	150W	200W	220W
B	16A	3	4	4	4	4	3
C	16A	6	7	7	6	6	6

According to MCB data sheet, the qty of luminaires in one Parallel connection is calculated at 230VDC

06.Repairs Maintenance

Visual tests and checks should be cared out at intervals described by the appropriate regulations, EN 60079-17, and should include the following (including but not limited to).

- Check for mechanical damage/corrosion.
- Check connections, fixings, glands and plugs.
- Check for undue accumulations of dust, dirt or moisture.
- Check for unauthorized modifications.

Periodic inspection of the enclosure seal should be checked out to ensure that the seal is sound. If the luminaire has been subject to abnormal conditions, for example, severe mechanical impact or chemical spillage, it must be de-energised until it has been inspected by an authorized and competent person.

07.Cleaning of luminaire

- The complete luminaire (without disassemble) can be cleaned with neutral water solution. After cleaning, rinse or wipe dry with clean water.
- It is forbidden to use any chemical or hydrocarbon solvent cleaner to clean the diffuser, otherwise serious damage may be caused.
- Please clean the luminaire once a year if it is used under dust environment.

08. Disposal of Material

General

Disposal of the luminaire as waste should be carried out in accordance with national regulations. Any disposal must satisfy the requirements of the WEEE directive [2012/19/EU] and therefore must not be treated as commercial waste. The unit is mainly made from incombustible materials. The control gear contains plastic, resin and electronic components. All electrical components may give off noxious fumes if incinerated.



To comply with the Waste Electrical and Electronic Equipment directive 2012/19/EU the apparatus cannot be classified as commercial waste and as such must be disposed of or recycled in such a manner as to reduce the environmental impact.

09. Transportation

Weatherproof measures should be taken during transportation.

It is strictly forbidden to load and unload violently, and it is strictly forbidden to drop and roll from high altitude, so as to prevent mechanical damage.

10. Storage

The luminaire should be stored in ventilated, non-dropping and non-liquid warehouse at the temperature of -20°C to $+40^{\circ}\text{C}$ and relative humidity $\leq 95\% \text{RH}$.

The surroundings should be kept from corrosive gases which may damage metal and insulation.

The battery should be fully charged and discharged at least once every 6 months.

Contact

SHENZHEN KHJ SEMICONDUCTOR LIGHTING CO., LTD.

Address: 4-5 Floor, Building 1, Chuangxin industrial park, Xintian community, Guanlan, Longhua new district, Shenzhen, China.

Tel: +86-755-82949977
E-mail: khjledsales@khj.cn

Web: www.khjled.com

Fax: +86-755-82949800
Web: www.khjled.com